

name	ODIL NXT CI
ref	390626 TEXTURED BLACK 2700K 10° 390726 TEXTURED BLACK 2700K 25° 390826 TEXTURED BLACK 2700K 46° 390636 TEXTURED BLACK 3000K* 10° 390736 TEXTURED BLACK 3000K* 25° 390836 TEXTURED BLACK 3000K* 46° 390647 TEXTURED WHITE 2700K 10° 390747 TEXTURED WHITE 2700K 25° 390847 TEXTURED WHITE 2700K 46° 390657 TEXTURED WHITE 3000K* 10° 390757 TEXTURED WHITE 3000K* 25° 390857 TEXTURED WHITE 3000K* 46°
safe distance to object	- 0,1m -
lamp / (lum.flux) / (color temp)	XP-G3 4x2W / (832lm/luminaire) / (2700K/3000K)*
fitting	No fitting
power	7,91W
voltage	230V AC 50Hz
symbol	
gear	Convertor integrated
ip/class	IP20
application	Interior - ceiling mounted
orientability	Not orientable
dimmability	Dimmable L or C (compatibility dimlist C)
weight	0.7
CRI	92
SDCM	3

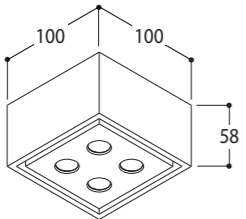

① Make drill patern to ceiling

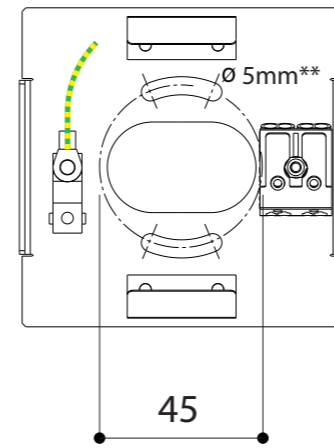
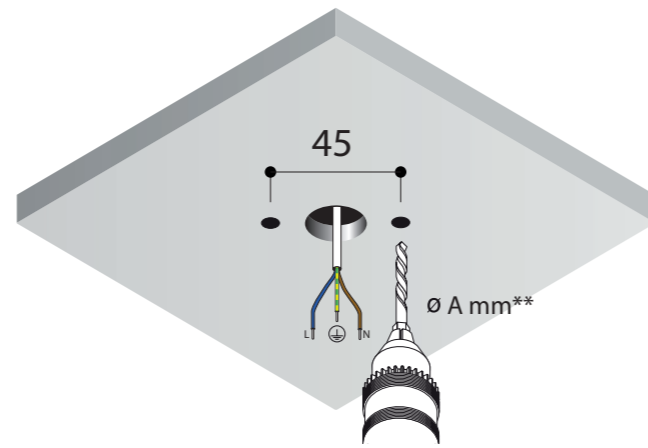

② Mount the ceiling bracket

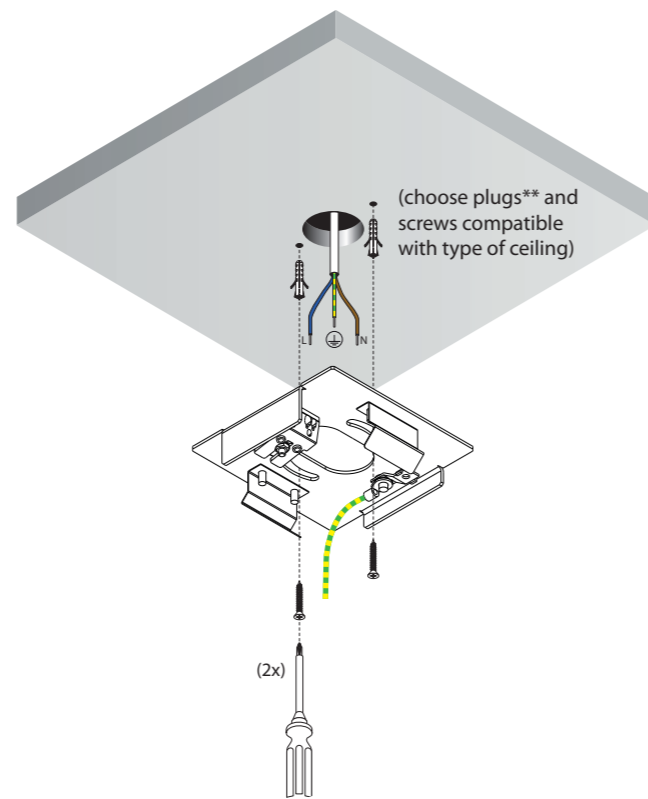

④ Connect the fixture to the ceiling bracket

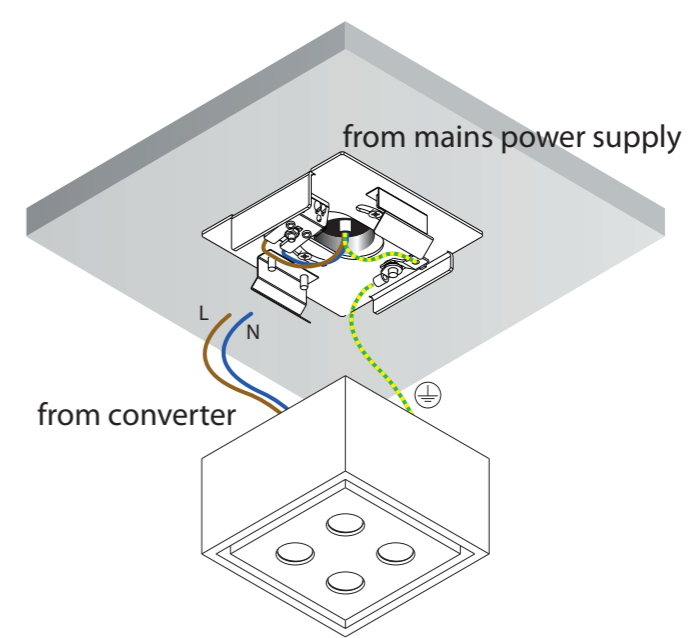

⑤ Click the fixture on the ceiling bracket and switch on mains power supply

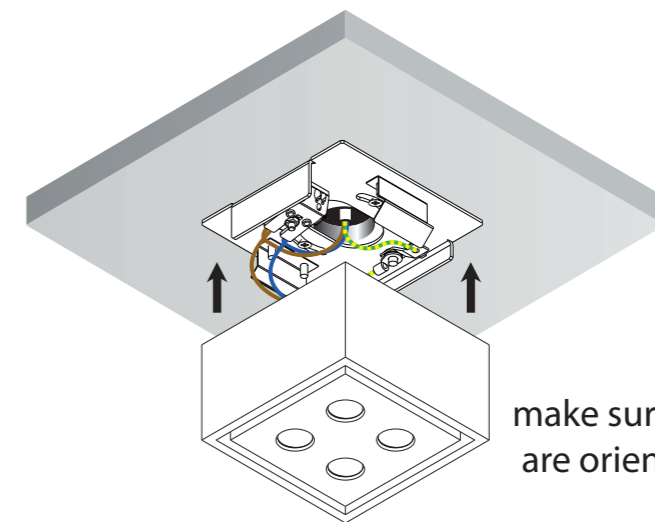

ATTENTION!
 make sure the leaf and snap system are oriented in the same direction:

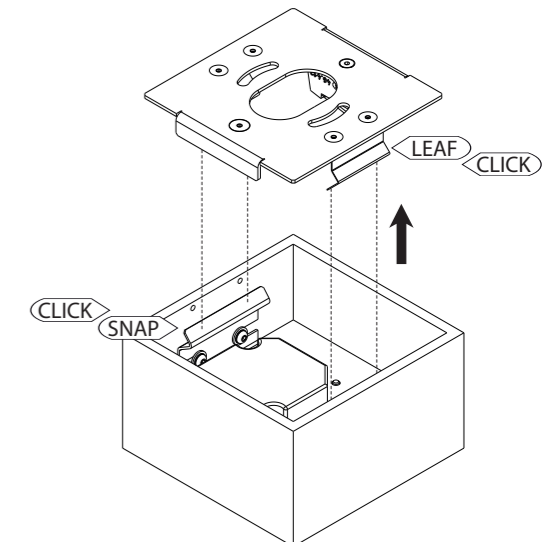

③ Connect to the mains power supply

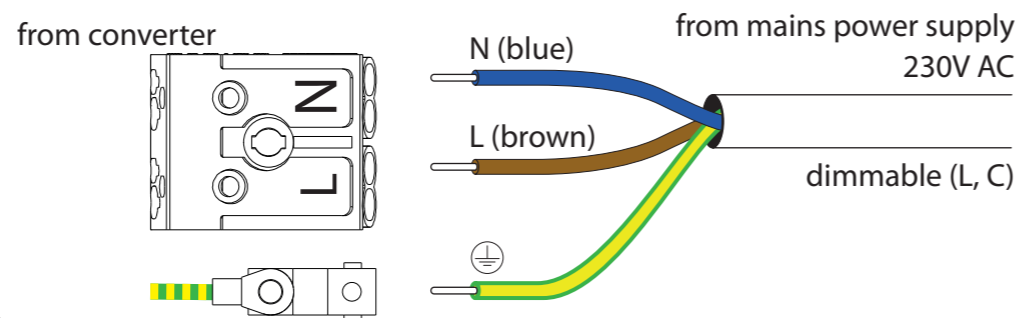

ALWAYS DISCONNECT MAINS POWER SUPPLY FROM CONVERTER BEFORE SWITCHING "ON" LED LUMINAIRES TO PREVENT HOT PLUGGING ISSUES

INSTALLATIE- EN ONDERHOUDSRICHTLIJNEN m.b.t. FABRIEKSGARANTIE.
 1. DE VERBINDINGEN EN HET UITTESTEN VAN DEZE TOESTELLEN DIENEN ALTIJD TE GEBEUREN DOOR EEN ERKENDE ELECTRO-INSTALLATEUR.
 2. DEZE VERLICHTINGSTOESTELLEN MOETEN GE*INSTALLEERD, VERBONDEN EN GETEST WORDEN VOLGENS DE NATIONAAL GELDENDE REGLEMENTEN OP DE ELECTRISCHE INSTALLATIES (BELGIE, A.R.E.I., DUITSLAND: DIN VDE 0100 TEIL 559 A2, ...; DEZE OPSOMMING IS LOUWER INFORMATIEF)
 3. DE TECHNISCHE BIJSLUITER MOET GEZIEN WORDEN ALS ONDERDEEL VAN DE ALGEMENE VERKOOPVOORWAARDEN VAN TAL N.V.
 4. DE ELECTRO-INSTALLATEUR IS VERANTWOORDELIJK VOOR HET GEBRUIKEN VAN VOORSCHAKELAPPARATUUR DIE VOLDOET AAN DE GELDENDE CE EN EMC NORMEN.
 5. VERVANG DE LAMP (-EN) ALTIJD MET DE GROOTSTE ZORG, ZE IS (ZIJN) UITERST BREEKBAAR.
 6. OPGEPAST: PLAATS NOOIT DE LAMP MET BLOTE HANDEN, GEBRUIK ALTIJD EEN DOEK!

INSTRUCTIONS D'INSTALLATION ET D'ENTRETIEN A RESPECTER VIS-A-VIS DE LA GARANTIE.
 1. LE PLACEMENT, LE RACCORDEMENT ET L'ESSAI DE CET APPAREIL DOIVENT TOUJOURS E*TRE EFFECTUES PAR UN INSTALLATEUR ELECTRICIEN AGREE.
 2. LES LUMINAIRES DOIVENT E*TRE INSTALLEZ, BRANCHES ET TESTES SUIVANT LE REGLEMENT NATIONAL SUR LES INSTALLATIONS ELECTRIQUES EN VIGUEUR. (BELGIQUE, A.R.E.I., ALLEMAGNE: DIN VDE 0100 TEIL 559 A2, ...; CETTE ENUMERATION EST INDICATIVE)
 3. CE MANUEL D'INSTALLATION TECHNIQUE REPRESENTE UNE PARTIE DES CONDITIONS GENERALES DEVENTE DE TAL N.V.
 4. L'ELECTRO-INSTALLATEUR EST RESPONSABLE POUR L'USAGE DE BALLASTS, TRANSFO'S,...CONFORMES AUX NORMES CE ET EMC EN VIGUEUR.
 5. REMPLACEZ TOUJOURS L'AMPOULE (LES AMPOULES) AVEC PRUDENCE; ELLE(-S) EST (SONT) TRES FRAGILE (-S).
 6. ATTENTION: NE JAMAIS REMPLACER L'AMPOULE AUX MAINS NUES, UTILISEZ TOUJOURS UN CHIFFON!

INSTALLATION AND MAINTENANCE INSTRUCTIONS IN VIEW OF THE MANUFACTURER'S GUARANTEE.
 1. THE CONNECTION AND TESTING OF THE DEVICES SHOULD ALWAYS BE PERFORMED BY A RECOGNIZED ELECTRICIAN.
 2. THESE LIGHTING DEVICES NEED TO BE INSTALLED, CONNECTED AND TESTED FOLLOWING THE OFFICIAL NATIONAL INSTRUCTION GUIDE FOR ELECTRICAL INSTALLATIONS (BELGIUM, A.R.E.I., GERMANY: DIN VDE 0100 TEIL 559 A2, ...; THIS ENUMERATION IS JUST AN INDICATION)
 3. THIS TECHNICAL ENCLOSURE NEEDS TO BE ADDED TO THE GENERAL SALES CONDITION OF THE TAL N.V.
 4. THE ELECTRO TECHNICIAN IS RESPONSABLE TO USE BALLASTS, TRANSFORMERS,...WHICH MEET THE VALID CE AND EMC RULES.
 5. ALWAYS REPLACE THE LAMP (-S) WITH UTMOST CAUTIONSNESS, THE LAMP (-S) IS (ARE) VERY FRAGILE.
 6. ATTENTION: NEVER REPLACE THE LAMP WITH BARE HANDS, ALWAYS USE A CLOTH!

MONTAGE- UN UNTERHALT INSTRUCTIONEN ZU BEACHTEN MIT BEZUG AUF DER GARANTIE.
 1. DIE MONTAGE , DER ANSCHLUSS UND DAS AUSTESTEN DER LEUCHTEN SOLL IMMER VON EINEM ZUSTAENDIGEN ELECTRO-INSTALLATEUR AUSGEFUHRT WERDEN.
 2. DIESE LEUCHTEN M*USSEN INSTALLIERT, ANGESCHLOSSEN UND GETESTET WERDEN NACH DER ALLGEMEINEN NAZIONALEN REGLEMENTATION UBER DIE ELEKTRISCHE INSTALLATIONEN (BELGIEN, A.R.E.I., DEUTSCHLAND: DIN VDE 0100 TEIL 559 A2, ...; DIESE AUFSTELLUNG GESCHICHT DURCH EXEMPLATIVEN TITEL UND KANN NICHT ALS LIMITATIV ODER EXHAUTIV BETRACHTET WERDEN).
 3. DIESE TECHNISCHE GEBRAUCHSANWEISUNG GEHORT ZU DEN ALLGEMEINEN VERKAUFSBEDINGUNGEN VON TAL N.V.
 4. DER ELEKTRO-INSTALLATEUR IST VERANTWORTLICH FUR DAS VERWENDEN VON CE UND EMC GEPRUFTE VORSCHALTGERATE.
 5. DIE LAMPE(-N) SOLL(-EN) IMMER SERH VORSICHTIG ERSAETZT WERDEN.
 6. VORSICHT: MAN DARF NIE DIE LAMPE MIT DEN NACKTEN HAENDEN BERUHREN, MAN SOL IMMER EINEN TUCH BENUTZEN!